

# DISTRIBUTION PRODUCTS / PRODUITS DISTRIBUTION

DRY TYPE GENERAL PURPOSE TRANSFORMER / TRANSFORMATEUR D'APPLICATION GÉNÉRALE DE TYPE SEC

CAT.	XD3C0075 S923232	
KVA	75	
PHASE	3	60 Hz
TEMP. RISE ÉLEV. TEMP.	115 °C	
TAPS PRISES	4 - 2.5 % 2A, 2B	
ENCLOS. BOITIER	3R	270 Kg

PRIMARY / PRIMAIRE	
VOLTAGE TENSION	CONNECTORS CONNECTEURS
480	#14 to/a #1/0

SECONDARY / SECONDAIRE	
VOLTAGE TENSION	CONNECTORS CONNECTEURS
208Y/120	1 of/de 500 MCM



DIMENSIONS		
	IN / PO	MM
A	33	(838)
B	29	(737)
C	15.75	(400)
D	17.25	(438)
E	--	(--)

IMPEDANCE / IMPÉDANCE *	3.59 (%)
NO LOAD LOSSES / PERTES À VIDE *	254.2 WATTS
LOAD LOSSES / PERTES EN CHARGE * (135 °C)	1887.1 WATTS
TOTAL LOSSES / PERTES TOTALES *	2141.3 WATTS
EXCITING CURRENT / COURANT D'EXCIT. *	1.5 (%)
NOISE LEVEL / NIVEAU DE BRUIT *	50 (dBA)
X/R RATIO / RATIO X/R *	1.01

INSULATION CLASS / CLASSE D'ISOLATION 220

\* ESTIMATED VALUES / VALEURS ESTIMÉES

\*\* MEETS / EXCEEDS CSA C802.2 EFFICIENCY

\*\* ÉGALE / DÉPASSE EFFICACITÉ CSA C802.2

% REGULATION (135 °C) * (FULL LOAD) (PLEINE CHARGE)			% EFFICIENCY / % EFFICACITÉ (135 °C) * (75 °C)**				
1.0 P.F.	0.9 P.F.	0.8 P.F.	100%	75%	50%	25%	35%
2.55	3.39	3.55	97.22	97.71	98.10	98.05	98.29

MOUNTING WALL / FLOOR

ANCRAGE : MUR / PLANCHER

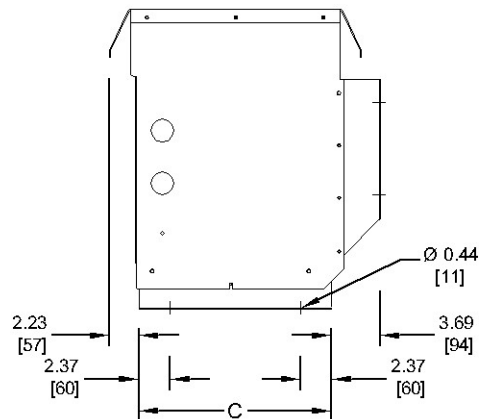
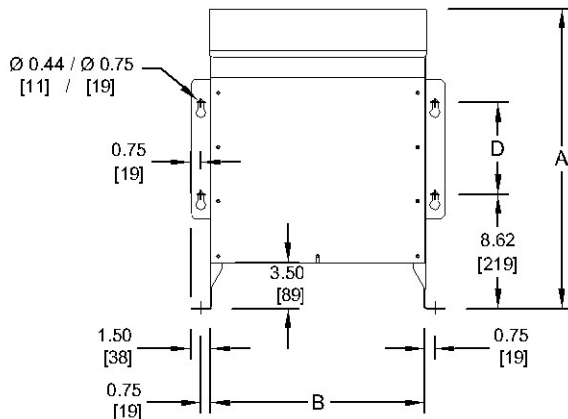

3 PHASE / 3 COIL / COPPER

3 PHASES / 3 BOBINES / CUIVRE



FOR PROPER VENTILATION FOR FLOOR INSTALLATION KEEP AT LEAST 6 INCHES FROM ADJACENT WALLS

POUR UNE BONNE VENTILATION LORSQUE INSTALLÉ AU SOL PLACEZ L'APPAREIL À AU MOINS 6 POUCHES DES MURS ADJACENTS

CUSTOMER CLIENT PO / BC		SPECIAL INST'N / INSTR. SPÉCIALE	
CONTR. PROJ.		Approved for installation in hazardous locations Class 1, Zone 2, Groups A, B, C and D temperature code T3 // Approuvé pour l'installation dans les endroits dangereux Classe 1, Zone 2, Groupes A, B, C et D code de température T3	
WO FT	DRAWING DESSIN	Ref. No 13369 V0001	 
DRAW. DESS.	Date 2015/06/05		
APPD. APP.	Date		
Tel : 1-800-663-3582 Fax : 1-877-449-9115			

Subject to change without notice / Sujet à changement sans préavis